



Typical Features

- ◆ Wide input voltage range 3:1
- ◆ Efficiency 85%(Typ.)
- ◆ Low standby power consumption
- ◆ Operating Temperature from -40°C to +105°C
- ◆ Isolation voltage 2500Vac(input-output) & 2100Vac(input-case)
- ◆ Input under-voltage protection, output OVP, SCP, OCP, OTP
- ◆ Standard 1/2 brick size

Conform to CE

ZBA200-220S28 is a high-reliability half brick size AC/DC module power supply with rated input voltage 220VAC(wide range 85-264VAC), no min-load limit, isolated & regulated single output 28VDC/200W, operating temperature 105°C Max, with input under-voltage protection, output over-current, over-voltage, over-temperature & short-circuit protections, the other functions of Sense for distal end compensation and Trim for output voltage adjustment, etc.

Typical Product List

Part No.	Input voltage range (VAC)	Output Power (W)	Output Voltage (VDC)	Output Current (A)	Ripple & Noise (mVp-p)	Full load Efficiency (%) Min/Typ.	Remark
ZBA200-220S28	85-264	200	28	7.15	280	83/85	Positive logic Standard
ZBA200-220S28-H							Positive logic With heat sink

Input Specifications

Item	Operating conditions	Min.	Typ.	Max.	Unit
Input current Max	Input 85VAC, full load	--	--	3	A
Input surge current Max	Input 220Vac, NTC(5.6R/Ø20mm) connected in series	--	--	20	A
Standby power consumption	Rated input voltage	--	--	2	W
Start-up voltage		--	--	85	VAC
Input inrush voltage (1S max.)	Unit could be permanently broken over this voltage	--	--	315	
Input under-voltage protection	No load	--	--	80	
Input voltage frequency		47	--	63	Hz
PF value	220Vac input, full load output	95	--	--	%

Output Specifications

Item	Operating conditions	Min.	Typ.	Max.	Unit
Output Voltage Accuracy	Rated input voltage, 10% load	--	±0.2	±1.0	%
Line Regulation	Full load, input voltage from low to high	--	±0.1	±0.2	
Load Regulation	Rated input voltage, 10%-100% load	--	±0.1	±0.2	
Transient recovery time	25% load step change (step rate 1A/50uS)	--	200	250	uS
Transient Response Deviation		-5	--	5	%
Temperature Drift Coefficient	Full load	-0.02	--	+0.02	%/°C
Ripple & Noise	20M bandwidth, test with ≥220uF capacitor	--	150	280	mVp-p

Output voltage adjustable (TRIM)		-10	--	+10	%
Distal end compensation (Sense)		--	--	105	%
Over temp protection	Temperature of the Metal base surface	105	115	125	°C
Output over voltage protection		125	--	140	%
Output over current protection		7.5	--	9	A
Output short circuit protection		Hiccup, continuous, self-recovery			

General Specifications

Item	Operating conditions		Min.	Typ.	Max.	Unit
Isolation Voltage	I/P-O/P	Test 1min, leakage current < 3mA	--	--	2500	VAC
	I/P-Case	Test 1min, leakage current < 3mA	--	--	2100	VAC
	O/P-Case	Test 1min, leakage current < 3mA	--	--	500	VDC
Insulation resistance	I/P-O/P	@ 500VDC	100	--	--	MΩ
Switching frequency			--	280	--	KHz
MTBF	MIL-HDBK-217F@25°C		150	--	--	K hours

Environmental characteristics

Item	Operating conditions		Min.	Typ.	Max.	Unit
Operating Temperature	See temperature derating curve		-40	--	+105	°C
Storage Humidity	No condensing		5	--	95	%RH
Storage Temperature			-40	--	+125	°C
Pin Soldering temperature	1.5mm from the case, < 1.5S		--	--	+350	
Cooling requirements			EN60068-2-1			
Dry and heat requirements			EN60068-2-2			
Moisture and heat requirements			EN60068-2-30			
Shock and vibration			IEC/EN 61373 C1/Body Mounted Class B			

EMC Performances (EN50155)

EMI	CE	EN50121-3-2	150kHz-500kHz 79dBuV		
		EN55016-2-1	500kHz-30MHz 73dBuV		
	RE	EN50121-3-2	30MHz-230MHz 40dBuV/m at 10m		
		EN55016-2-1	230MHz-1GHz 47dBuV/m at 10m		
EMS	ESD	EN50121-3-2	Contact ±6KV/Air ±8KV		perf. Criteria A
	RS	EN50121-3-2	10V/m		perf. Criteria A
	EFT	EN50121-3-2	±2kV 5/50ns 5kHz		perf. Criteria A
	Surge	EN50121-3-2	line to line ± 1KV (42Ω, 0.5μF)		perf. Criteria A
	CS	EN50121-3-2	0.15MHz-80MHz 10 V r.m.s		perf. Criteria A

Physical Characteristics

Case Materials	Metal base + Plastic case in black with flame class UL94 V-0
Heat sink	Dimension 61.0x57.9x15.0mm, weight 65g, Aluminium, anodized black
Cooling method	Conduction cooling or forced fan cooling
Weight	Standard 120g, with heatsink 188g

Mechanical Dimensions and Pin-Out

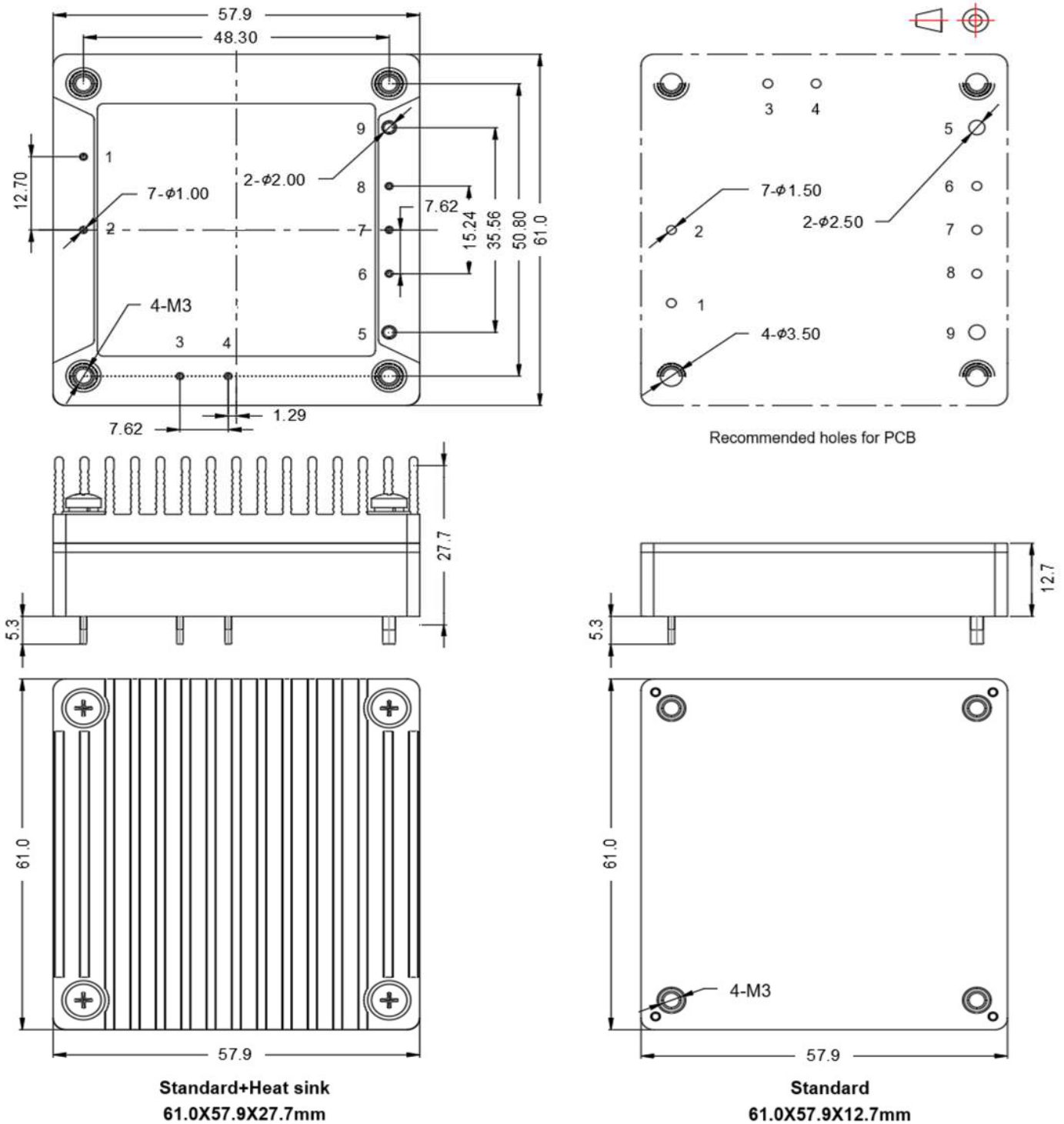

Standard+Heat sink
61.0X57.9X27.7mm

Standard
61.0X57.9X12.7mm

Note:
Unit: mm
Pin 1,2,3,4,6,7,8 diameter: 1.00
Pin 5,9 diameter: 2.00
Tolerance: .X \pm 0.5, .XX \pm 0.1
Screwing torque: 0.4N.m Max.

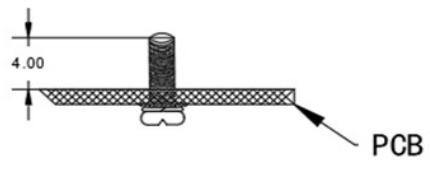

No.	1	2	3	4	5	6	7	8	9
Pin-out	AC1	AC2	BC+	BC-	Vout+	+S	TRIM	-S	Vout-
Function	Input AC1	Input AC2	PFC C+	PFC C-	Output V+	Sense +	TRIM	Sense -	Output V-

Product Performance Curve

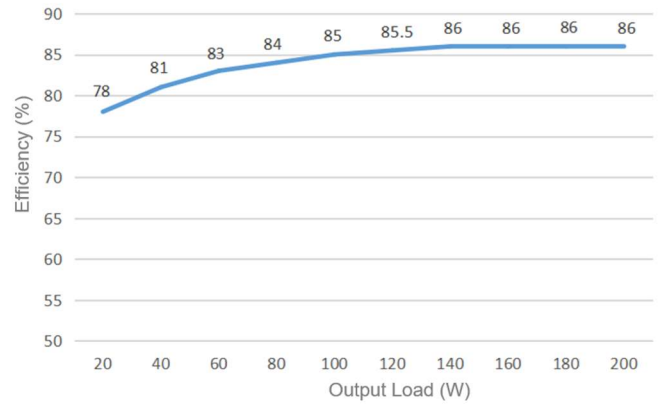
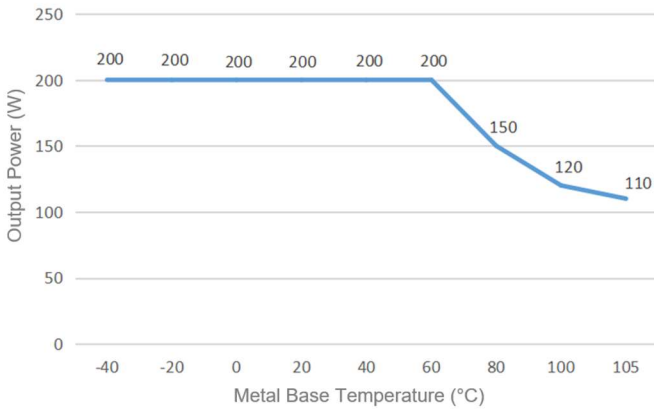

Note:

- Both the temperature derating curve and the efficiency curve are tested with typical values
- The data in temperature derating curve had been tested at Aipu laboratory test conditions. It is recommended to keep the temperature of the Metal base not more than 100 °C when the converter operates at the rated load for the customer application.

Recommended circuits for application

1. Ripple & Noise

All the products will be tested according to this circuit before shipping.

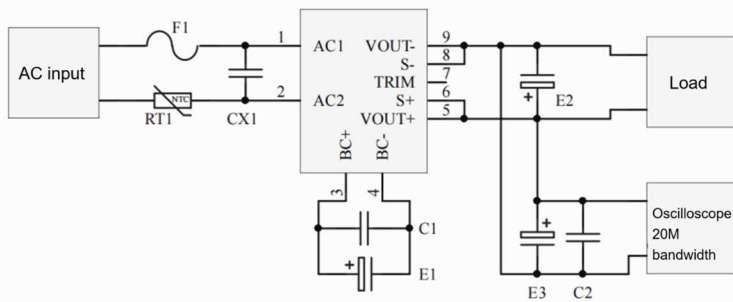

Vo	E1 (uF)	E2 (uF)	C1 (uF)	C2 (uF)	E3 (uF)
3.3VDC	100uF	1000uF	1uF/520V	1uF	10uF
5VDC		680uF	1uF/520V		
12VDC		470uF	1uF/520V		
.....		220uF	1uF/520V		
48VDC		220uF	1uF/520V		
.....		68uF	1uF/520V		
110VDC			1uF/520V		

2. Recommended for application

If this recommended circuit is not adopted, C3X should be $\geq 0.47\mu\text{F}$, E1 should be $\geq 100\mu\text{F}$, NTC must be used, C1 should be $\geq 1\mu\text{F}$ at the temperature $\leq -25^\circ\text{C}$. The power supply could be fail if these conditions are not met.

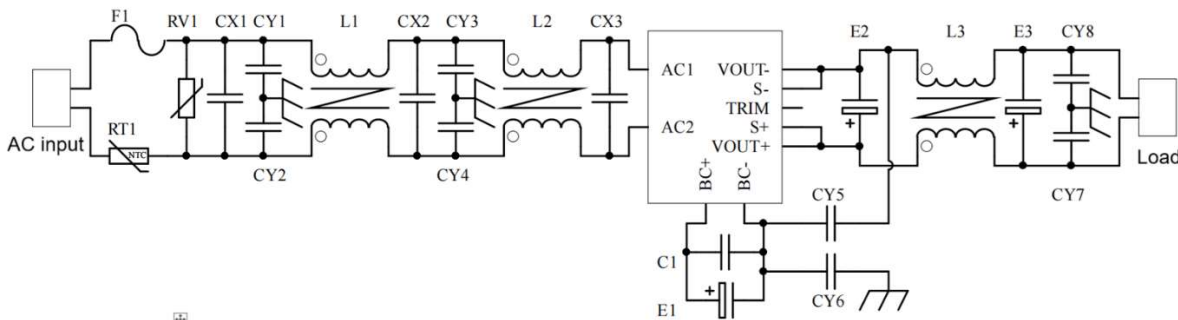

F1	T6.3A/250V FUSE
RV1	10D 620V TVS
RT1	5.6Ω/Ø20mm NTC
X1,CX2,CX3	224/250VAC/X2 Capacitor
CY1,CY2,CY3,CY4,CY5	102/250Vac/Y2 Capacitor
CY7,CY8	103/2KV Ceramic Capacitor
CY6	471/250Vac/Y1 Capacitor
C1	105/630V Polyester Film Capacitor
E1	220μF/450V Electrolytic capacitor
E2, E3	220μF/35V Electrolytic capacitor
L1,L2	>8mH, the temperature rise <25°@3A
L3	>0.5mH, the temperature rise <25°@7.2A

3. Application for Sense

1) With NO distal end compensation

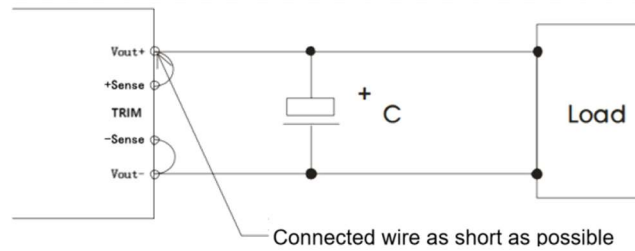

Notes:

1. Vout+ & Sense+, Vout- & Sense- should be shorted when distal end compensation is not needed
2. The lead wire between Vout+ and Sense+, Vout- and Sense- should be as short as possible, and close to the pins, or else the output may be unstable.

2) With distal end compensation

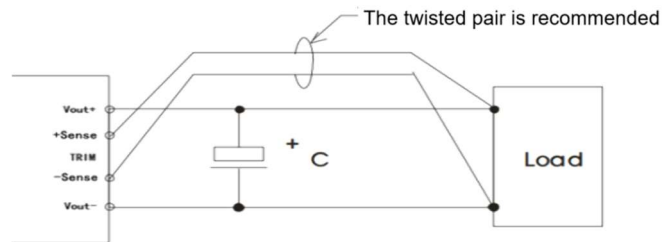

Notes:

1. The output voltage may be unstable if the compensation cables are too long.
2. Twisted pair or shielded cables is recommended, the cable length should be as short as possible.
3. Wide copper path on PCB or thick lead wires between the power supply and the load should be used to achieve the line voltage drop <0.3V. The target is to keep output voltage within the specified range.
4. The leads wire resistance may create the output voltage oscillation or larger ripples. Please verify it before to use.

4. TRIM & TRIM resistance calculation

The calculation of ΔU and R_{up} & R_{down} :

$$R_{up} = 70 / \Delta U - 5.1 \text{ (K}\Omega\text{)}$$

$$R_{down} = 28 * (25.5 - \Delta U) / \Delta U - 5.1 \text{ (K}\Omega\text{)}$$

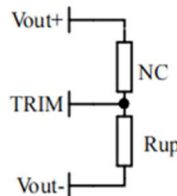

Voltage-up: Add R_{up} between Trim and Vout-

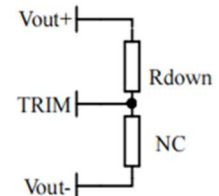

Voltage-down: Add R_{down} between Trim and Vout+

5. This product is not available for connecting in parallel to increase the output power. Please contact Aipu technician for this kind of application requirement.

Others

1. The product warranty period is two years. The failed product can be repaired/replaced free of charge if it operates at normal condition. A paid service shall be also provided if the product failed after operating under wrong or unreasonable conditions.
2. Aipupower can provide customization design and filter modules for matching, please contact our technician for details.

Guangzhou Aipu Electron Technology Co., Ltd

Address: Building 4, HEDY Park, No.63, Punan Road, Huangpu Dist, Guangzhou, China.

Tel: 86-20-84206763 Fax: 86-20-84206762 HOTLINE: 400-889-8821

E-mail: sales@aipu-elec.com Website: <https://www.aipupower.com>